



PERSONAL COMPUTERS

FOLDERS, DOCUMENTS, FILES & BACKUPS



FOLDERS, DOCUMENTS AND FILES

- ✘ Use *My Documents* (W7 – *Documents*)
- ✘ Make A New Folder
- ✘ Save Something In A Folder
- ✘ Copy And Delete Files
- ✘ Change The Name Of A File
- ✘ Empty The *Recycle Bin*
- ✘ Copy File To A CD, DVD, Or Memory Stick



MY DOCUMENTS FOLDER

- ✘ Each User Account Has A “My Documents” Folder (*W7 – Documents*)
- ✘ Click On Start, Then Click On My Documents

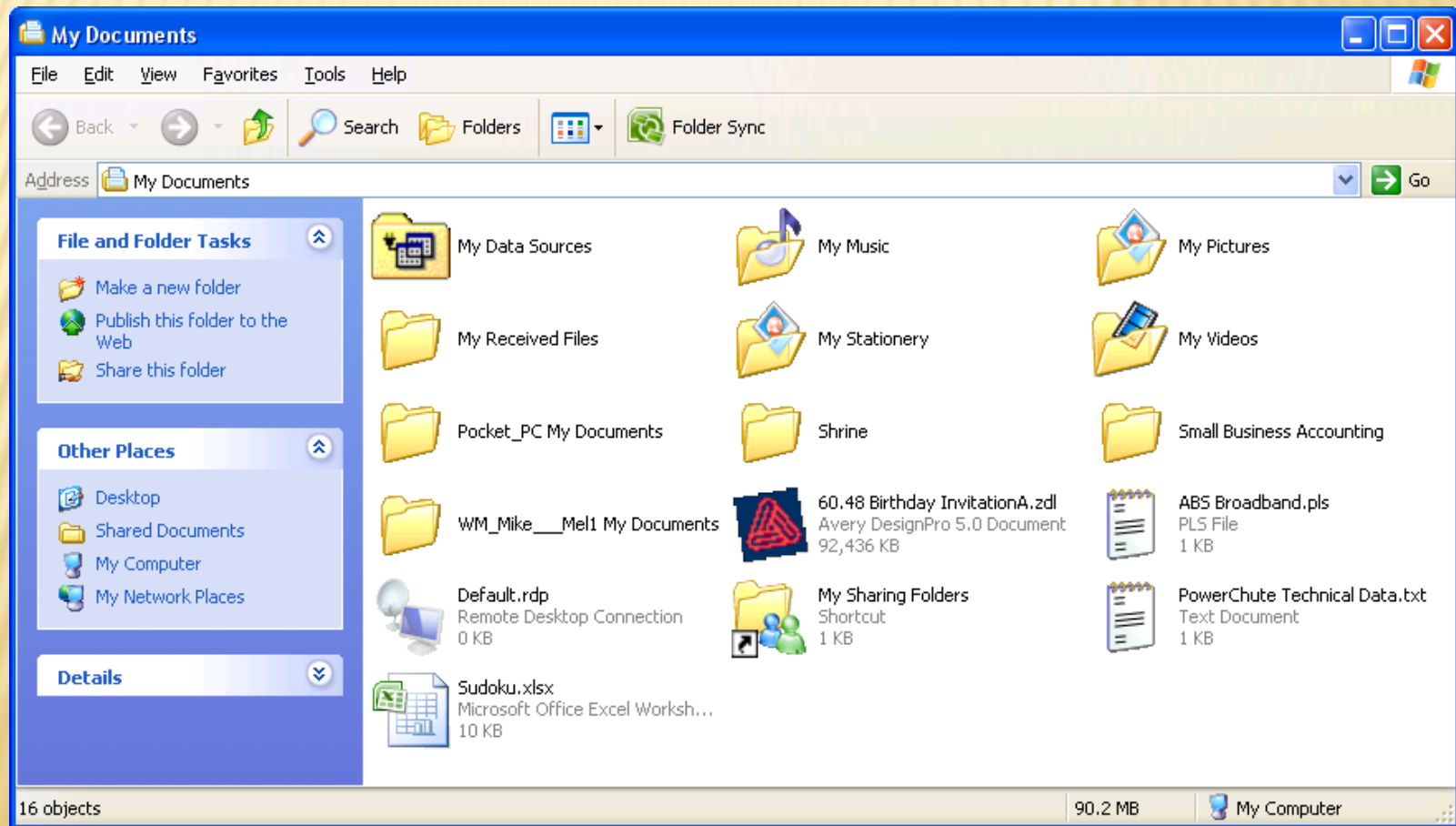



PURPOSE OF MY DOCUMENTS FOLDER

- ✘ Common Location To House All User Folders, Files And Documents
- ✘ Hierarchical Tree Structure – Very Organized
- ✘ Organization Structure Up To User

- ✘ Shared Exercise – Describe Methods You Use To Organize And File Information At Home



MY DOCUMENTS FOLDER DEFAULT

- ✘ Anticipates You Will Want To Save Music, Pictures And Videos
- ✘ Add Folders To Organize Your Information
- ✘ Much Like One Would Use An Office, File Cabinets, Drawers, Folders And Files
- ✘ Files May Be Stored In Any Folder
- ✘ Just Like Home, They Can Be Mis-Filed

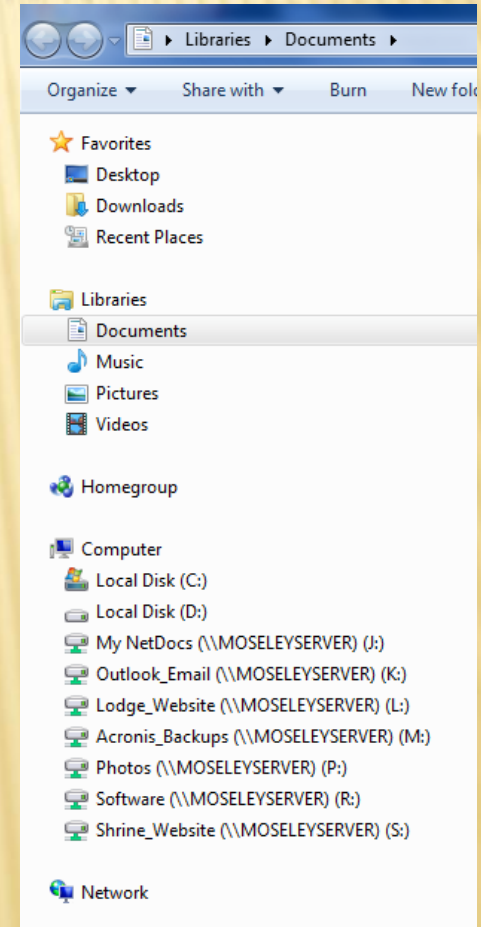
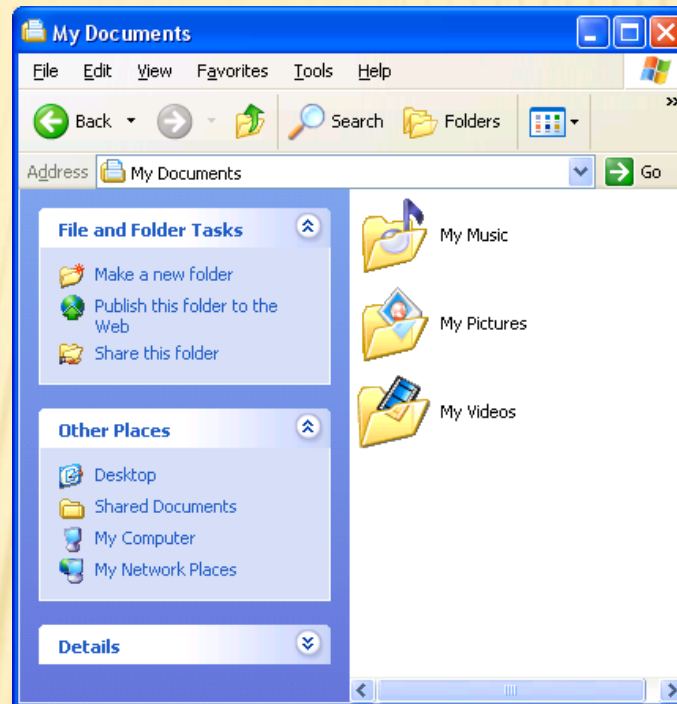



FOLDER STRUCTURE SIMILAR TO OFFICE

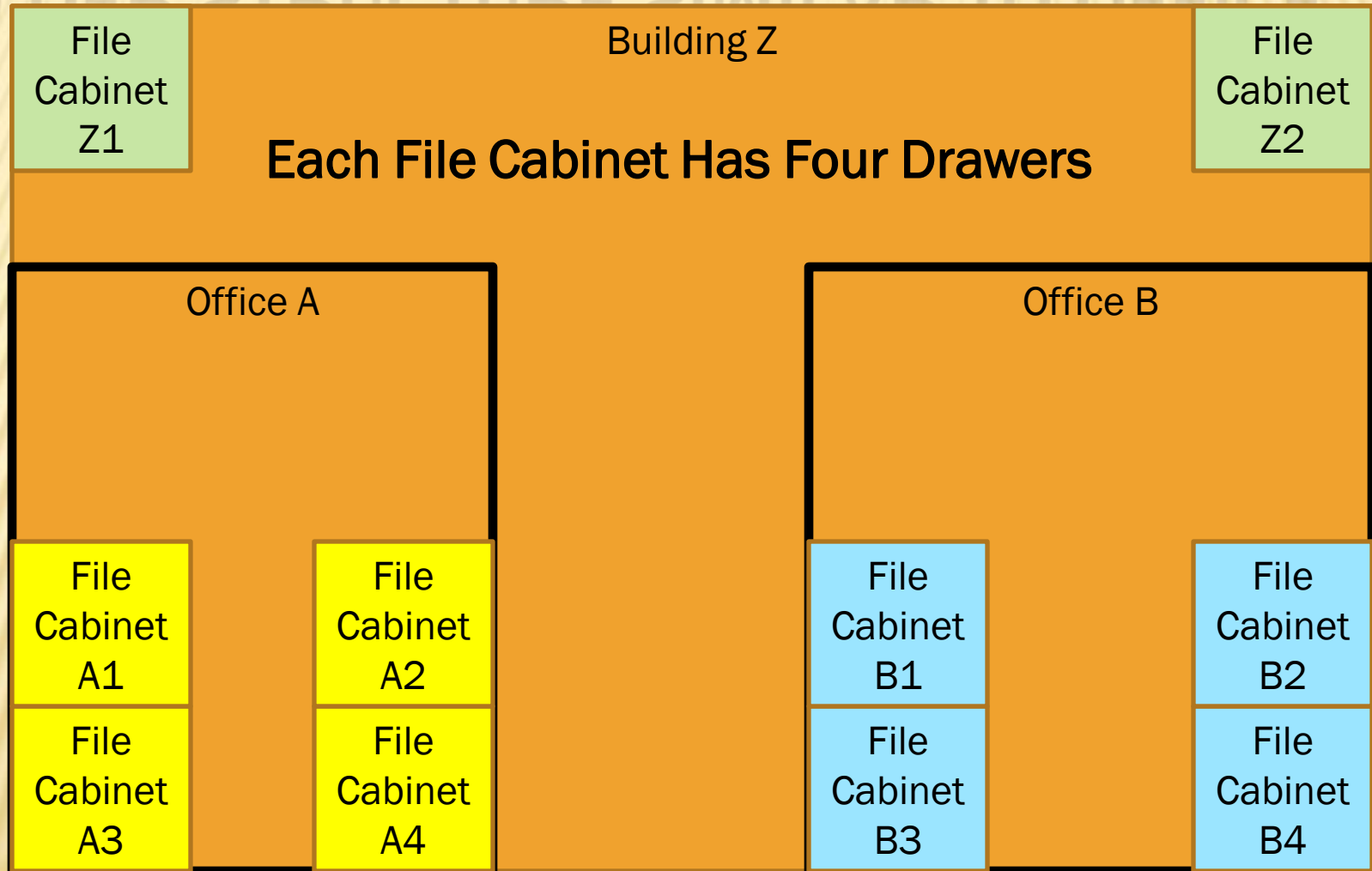

What Does The Folder Structure Look Like?



OFFICE FOLDER STRUCTURE

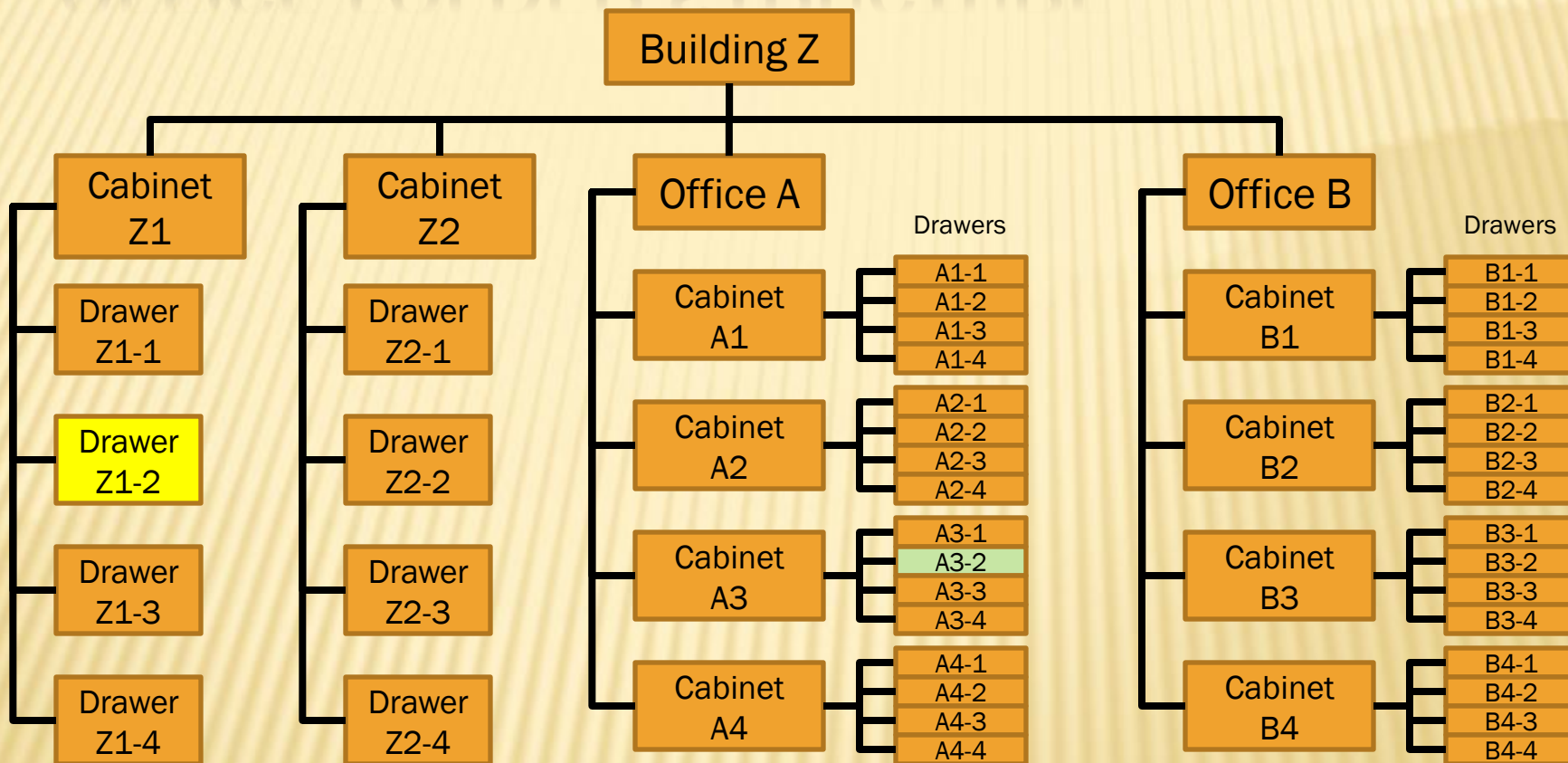

File In Cabinet Drawer Z1-2 Is Named:
 \\Building Z\Cabinet Z1\Drawer Z1-2\

File In Cabinet Drawer A3-2 Is Named:
 \\Building Z\Office A\Cabinet A3\Drawer A3-2\

Files And Folders At Same Level
 Must Have Unique Names No
 Longer Than 255 Characters



MAKING A NEW FOLDER

- ✘ Click On



Make a new folder

- ✘ Type: Letters

- ✘ Press Enter

- ✘ Use This To Save Letter Saved From WordPad

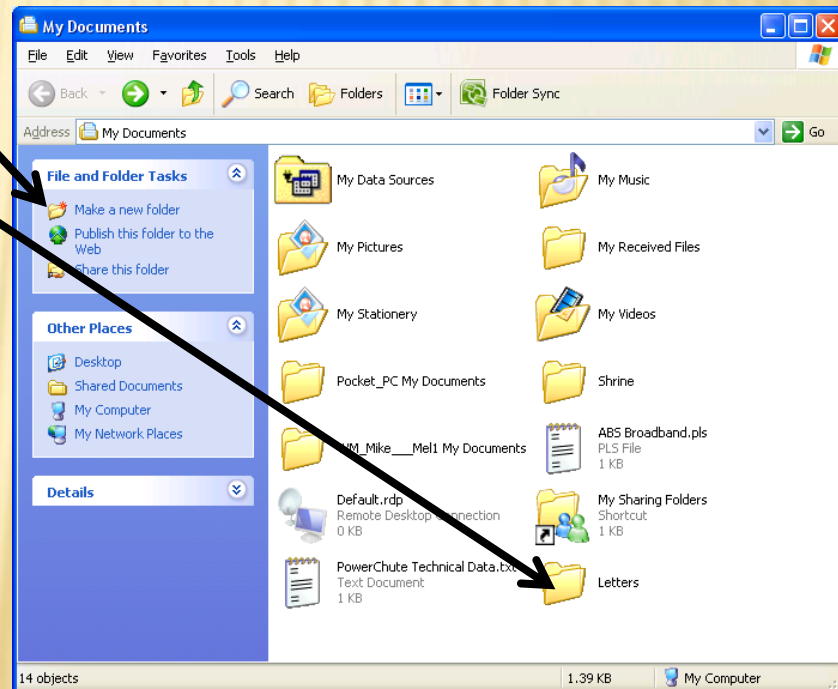
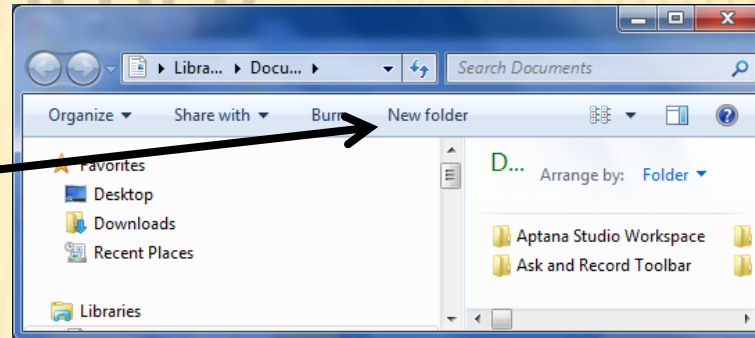



SAVING IN A FOLDER

- ✘ Start WordPad
- ✘ Type: Letter To Be Saved
- ✘ Click On File
- ✘ Click On Save
- ✘ My Documents Listed In Save In Box
- ✘ Double Click On Letters Folder

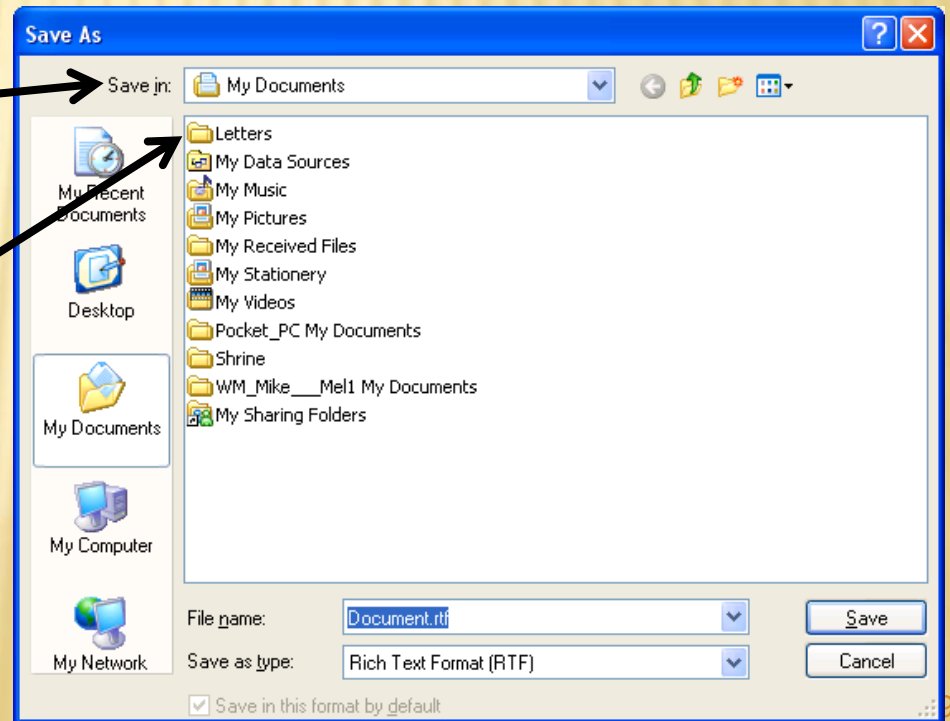
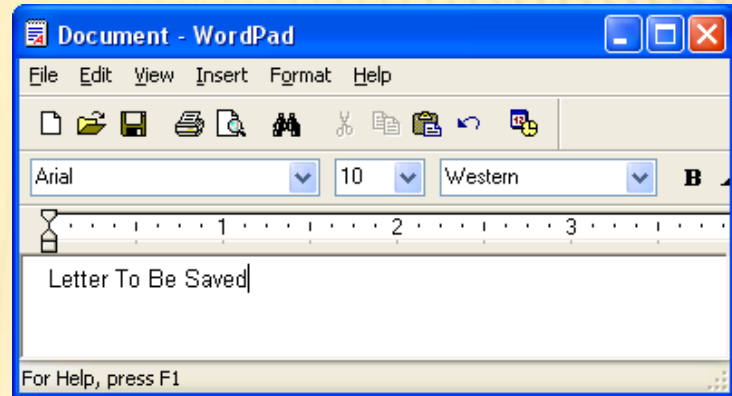



SAVE TO LETTERS FOLDER

✘ Letters In Save In Box

✘ Replace File Name
“Document” With
“Save File Exercise”

✘ Click On Save

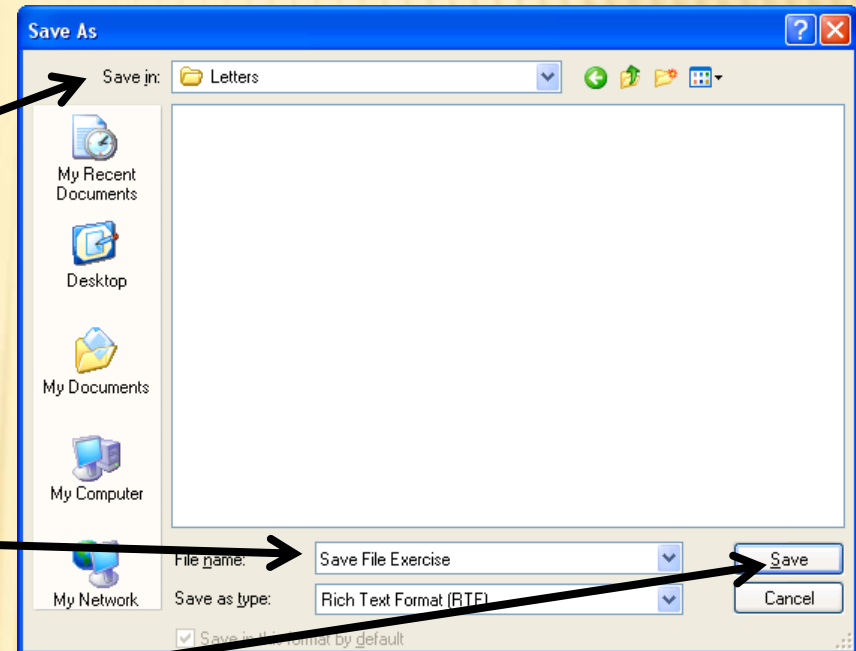



FILE SAVED TO LETTERS FOLDER

✘ File Name Appears In Title Bar

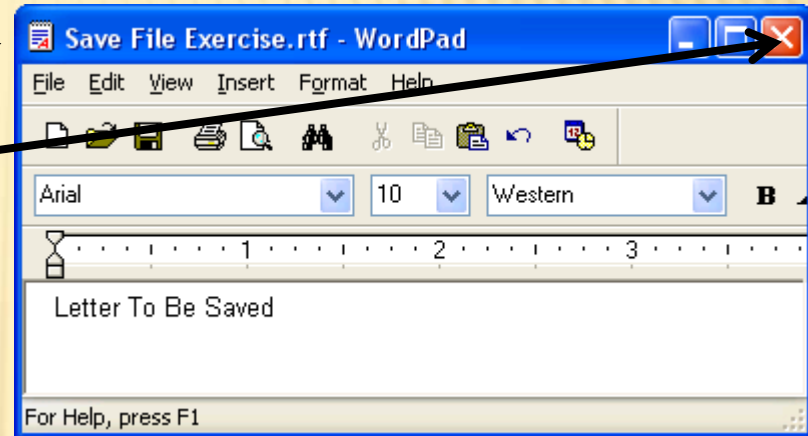

✘ Close Word Pad

✘ Complete Folder Name
In Title Bar

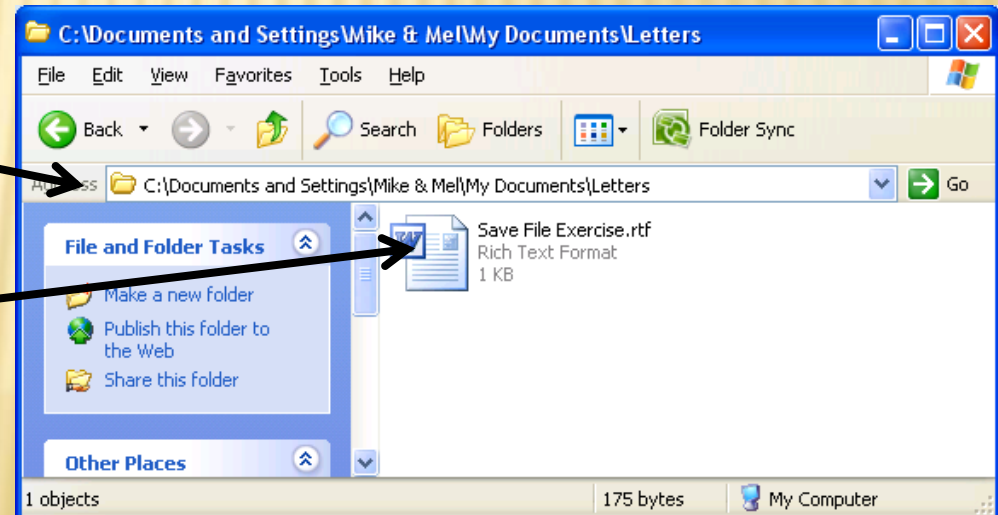

✘ File Is In Letters Folder



OPEN FILE FROM FOLDER

- ✘ Click On Start
- ✘ Click On My Documents
- ✘ Double Click On "Letters" Folder
- ✘ Double Click On "Save File Exercise"
- ✘ WordPad Opens
Save File Exercise File
- ✘ Close WordPad

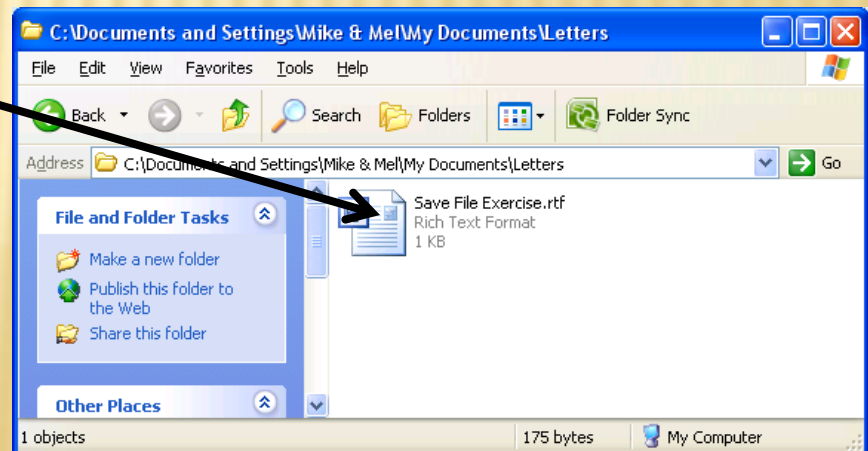
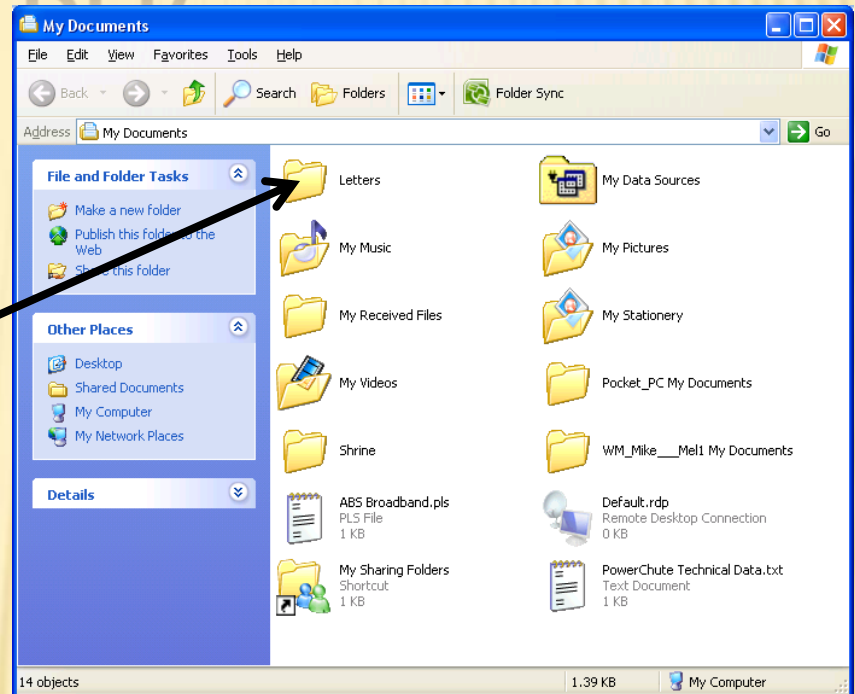



COPYING FILES

✘ Right-Click On Save File Exercise

✘ Click On Copy

✘ Click On Up Button
(Goes Up One Level In Structure)

✘ Right-Click In White Space

✘ Click On Paste

✘ File Is Copied

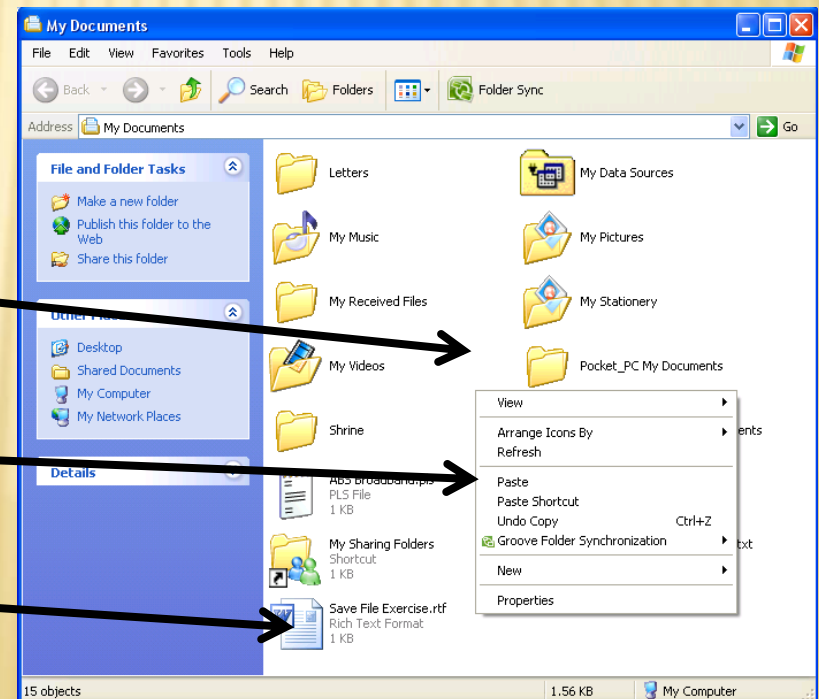
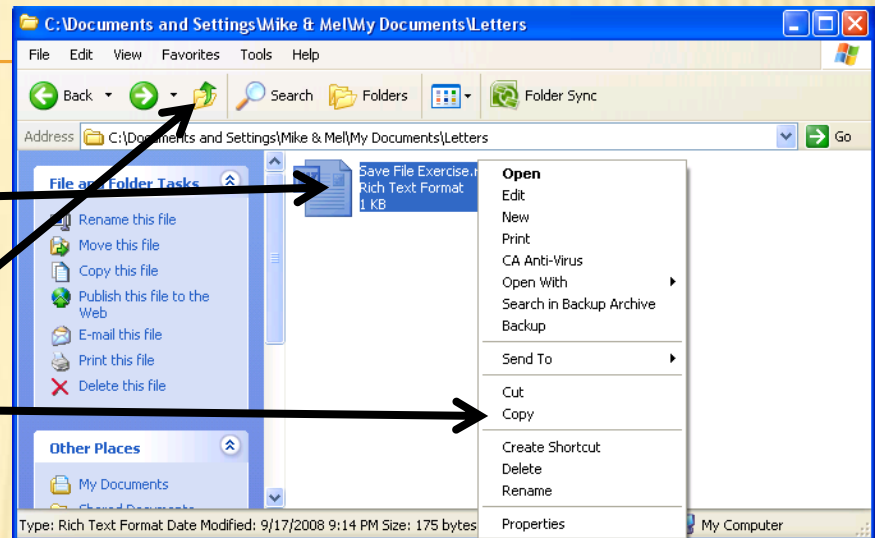



CHANGING FILE NAMES

- ✘ Click Once On **“Save File Exercise”** And **Pause**

- ✘ Click Once On **“Save File Exercise”** Filename

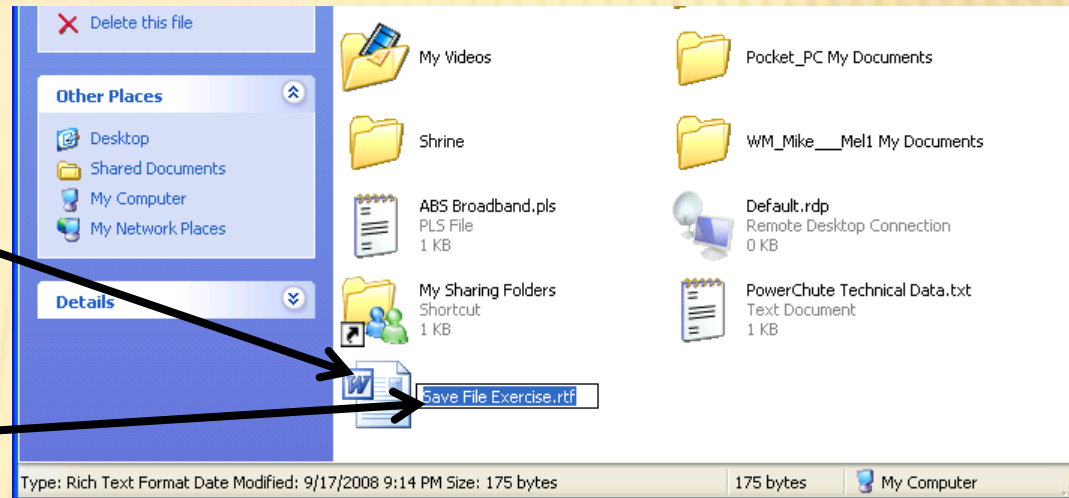

- ✘ Type **“Exercise 1”** (If Filename Had **“.rtf”** At The End, Add It On The End)

- ✘ Press **Enter** Or Click In White Space

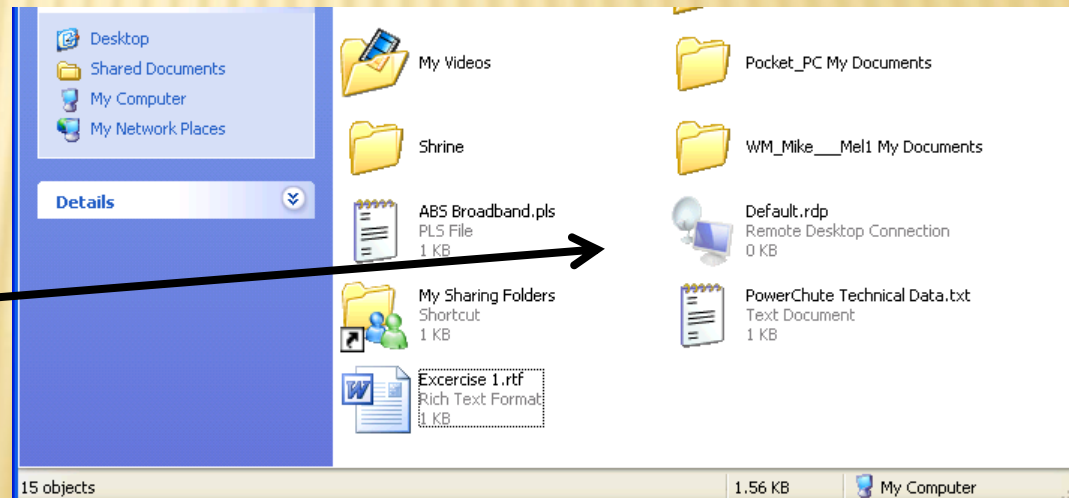



DELETING FILES

- ✘ Click On “Exercise 1”
- ✘ Press Delete Key

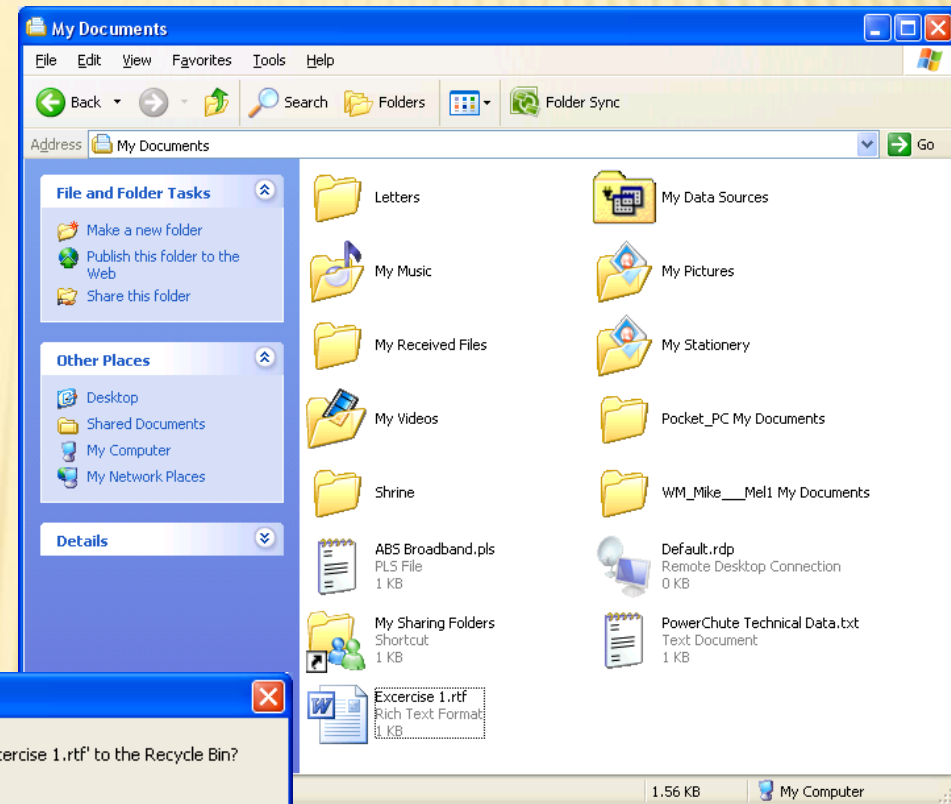
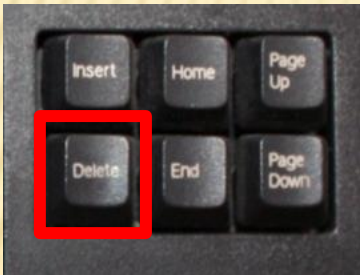

- ✘ Click On Yes

- ✘ File Goes To Recycle Bin



UNDELETING FILES

- ✘ Go To Desktop – Press And Hold “Window” Key And Press “D” Key Together



Two “Windows” Keys
Either One Works

- ✘ Double Click On Recycle Bin
- ✘ Right Click On Exercise 1 File
- ✘ Click On Restore
- ✘ File Returns To My Documents Folder

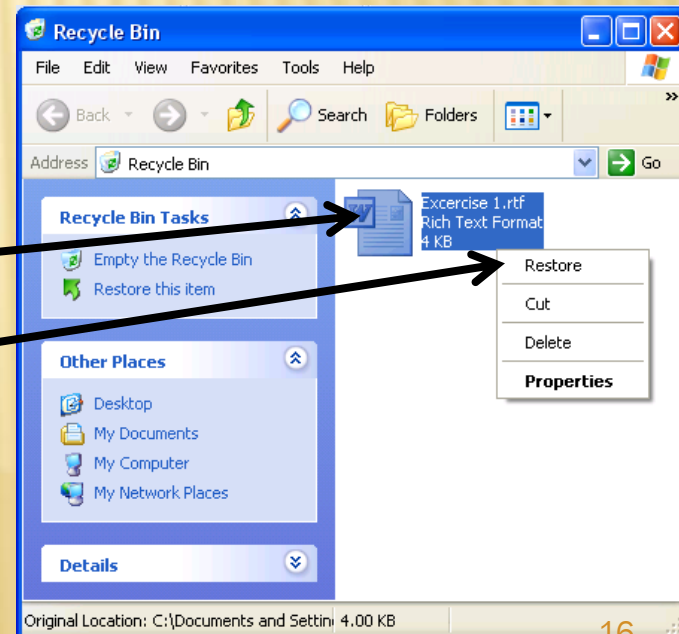



COPY FILE TO USB MEMORY STICK

- ✘ Insert USB Memory Stick In USB Port (Found On Front, Back Or Side Of PC)



- ✘ After New Window Comes Up, Open My Documents

- ✘ Click And Drag Exercise 1 File To USB Window And Release Mouse Button

- ✘ This Method Works To Copy Files From Any Folder To Another Folder

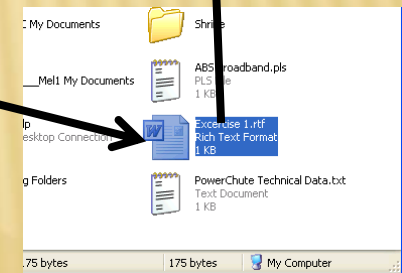
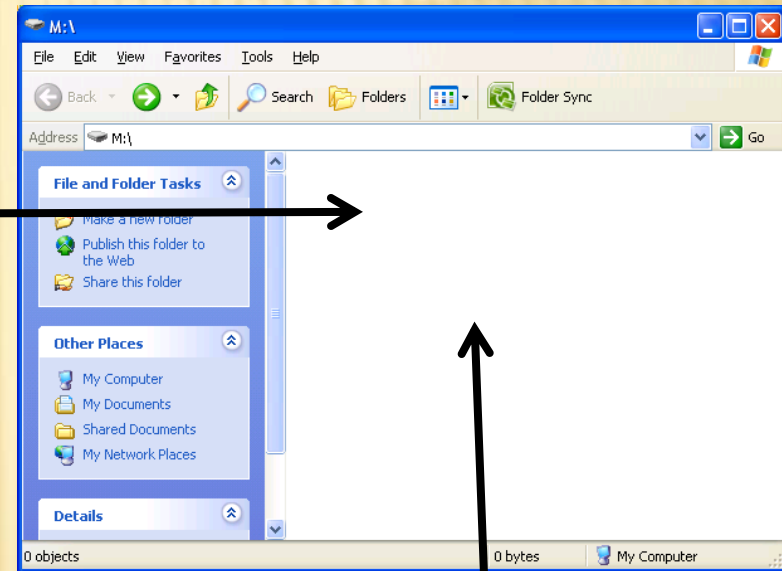



EXERCISES

- ✘ Start *My Documents*
- ✘ Open The Folder *Letters*
- ✘ Open The Folder *My Documents* Again
- ✘ Close *My Documents*
- ✘ Start *My Documents*
- ✘ Create A New Folder *Practice*
- ✘ Close *My Documents*



EXERCISES

- ✘ Start *My Documents*
- ✘ Copy The Practice File *Exercise 1* To The Folder *Practice*
- ✘ Close *My Documents*
- ✘ Start *My Documents*
- ✘ Open The New Folder *Practice*
- ✘ Change The Name Of The Practice File *Exercise 1* To *Song*
- ✘ Close *My Documents*



EXERCISES

- ✘ Start *My Documents*
- ✘ Open The New Folder *Practice*
- ✘ Delete The Practice File *Song* In This Folder
- ✘ Close *My Documents*
- ✘ Start *My Documents*
- ✘ Copy The Practice File *Exercise 1* To The *USB Memory Stick*
- ✘ Close *My Documents*